

**MURPHY**<sup>®</sup>

by **ENOVATION** CONTROLS



# PowerView<sup>®</sup> Model PV485

*Installation Manual*

---

00-02-1018  
2017-05-23  
Section 78

In order to consistently bring you the highest quality, full-featured products, we reserve the right to change our specifications and designs at any time. The latest version of this manual can be found at [www.murphybynovationcontrols.com](http://www.murphybynovationcontrols.com).

**Warranty** - A limited warranty on materials and workmanship is given with this Murphy product. A copy of the warranty may be viewed or printed by going to [www.murphybynovationcontrols.com/warranty](http://www.murphybynovationcontrols.com/warranty)



**BEFORE BEGINNING INSTALLATION OF THIS MURPHY PRODUCT:**

- Read and follow all installation instructions.
- Please contact Enovation Controls immediately if you have any questions.
- A visual inspection of this product for damage during shipping is recommended before installation.
- It is your responsibility to ensure that qualified mechanical and electrical technicians install this product.

Contact Enovation Controls' Technical Service if you have any questions or concerns at: +1 918-317-4100.

## Table of Contents

<b>Hardware Installation</b> .....	<b>1</b>
Inspecting Package Contents.....	1
Tools needed. ....	1
Dash-Mounted Installation.....	1
Rear-Mounted Installation (Optional) .....	2
<b>Wiring Instructions 4</b>	
PIN Specifications for AMPSEAL Style Connection .....	4
Accessories.....	4
<b>Configuration Information</b> .....	<b>5</b>
<b>Specifications</b> .....	<b>6</b>
Technical.....	6
Environmental .....	6
Mechanical .....	6
<b>Mounting Templates</b> .....	<b>7</b>
Dash-Mount Template.....	7
Rear-Mount Bracket Template .....	9
<b>PV485 Connection with Power</b> .....	<b>11</b>

**(THIS PAGE INTENTIONALLY LEFT BLANK)**

## Hardware Installation

The following instructions will guide you through installing the PV485 display.

### Inspecting Package Contents

---

Before attempting to install the product, it is recommended that you ensure all parts are accounted for and inspect each item for damage (which sometimes occurs during shipping). The items included in the box are:

Installation kit – P/N 78-00-0783 includes:

- 4 (8-32) mounting studs
- 4 (8-32) Keps Nuts
- 1 small bag

### Tools needed.

---

- Drill with 3/16" size bit
- Jig Saw
- Wrench or socket for (8-32) Keps nuts

## Dash-Mounted Installation

---

### Preparing the Dash

Determine the location of the PowerView 485 in the dash. Use the Installation Template (included at the end of the manual) as a guideline to cut a hole in the dash to the specified dimensions. Drill holes where indicated on the template for the mounting screws.

**NOTE:** When using the paper template from the manual, please be aware that if you downloaded this document from the Murphy by Enovation Controls website, the pdf file may not automatically print to scale. When submitting the file for print, you will need to select "None" for Page Scaling. Check the accuracy of the printed template by verifying the measurements labeled on the template are correct.

If this manual was supplied with your product, the template will be correct.

## Installing the Display

Place the back side of the display through the opening in the dash.

1. Use the 4 screws to line up the unit with the drilled holes.
2. Push the unit through the opening and screws through the drilled holes until the back of the case is flush.
3. Use the Keps nuts provided to tighten unit to the dash. Use the appropriate wrench or socket to tighten. Torque lock nuts to 8-10 inch pounds.

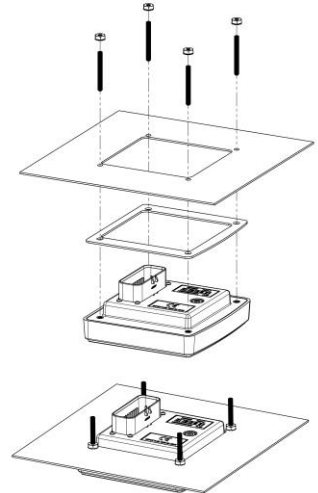
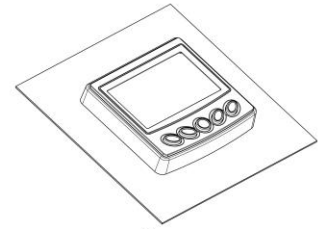

## Rear-Mounted Installation (Optional)

Attach the Rear-mount bracket (P/N 78-00-0815) to the backside of the unit.

1. Use the 4 screws to line up the rear-mount bracket with the drilled holes.
2. Push the unit through the opening and screws through the drilled holes until the back of the case is flush.
3. Use the Keps nuts provided to tighten unit to the dash. Use the appropriate wrench or socket to tighten. Torque lock nuts to 8-10 inch pounds.

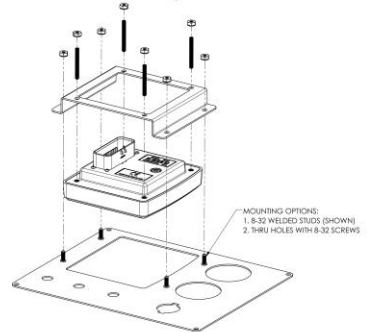
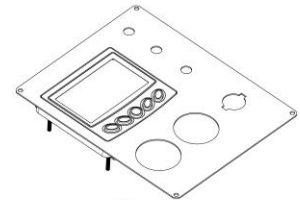

## Mounting Options

### Screws

1. Use the Installation Template (included at the end of the manual) as a guideline to cut a hole in the mounting plate to the specified dimensions and drill holes where indicated on the template for the mounting screws.
2. Place the display behind dash and line up the four mounting holes on the rear-mount bracket with the holes in dash.
3. Install four 8-32 screws (not provided) and torque lock nuts to 8-10 inch pounds.

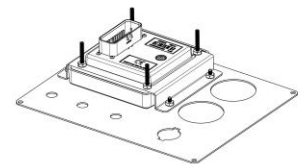

## Studs

1. Use the Installation Template (included at the end of the manual) as a guideline to cut a hole in the mounting plate to the specified dimensions and weld 8-32 studs where indicated on the template for mounting.

NOTE: Weld Studs and nuts are not provided. 8-32 Keps Nuts, Lock Nuts, or Nuts with lock washers would need to be used.

2. Place the display behind dash and line up the four 8-32 welded studs with the holes in rear-mount bracket.
3. Torque lock nuts to 8-10 inch pounds.

## Dimensions for Installation

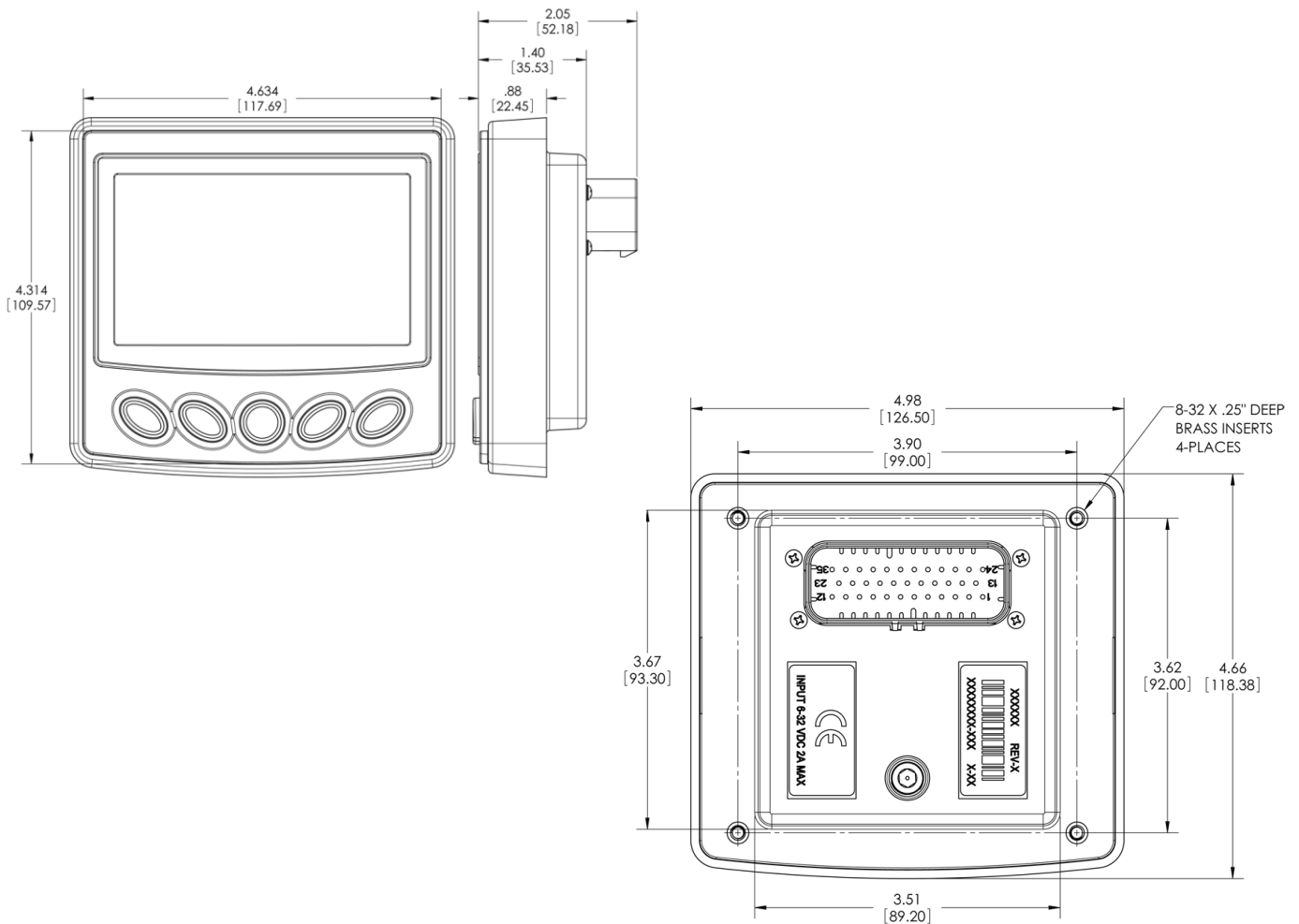

# Wiring Instructions

## PIN Specifications for AMPSEAL Style Connection

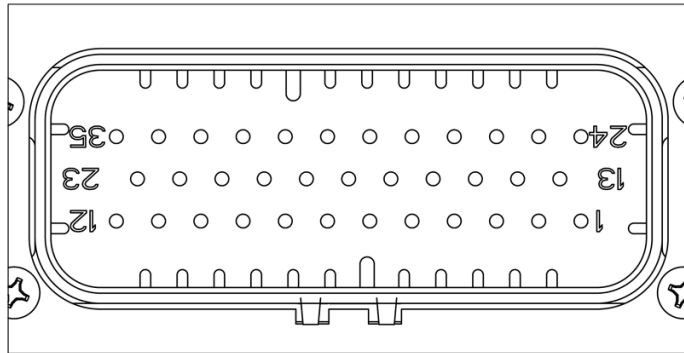
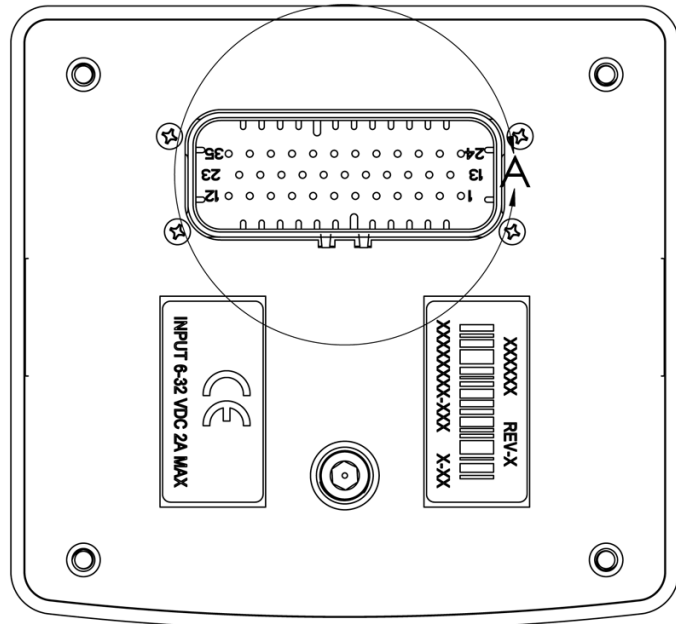

DETAIL A  
SCALE 2 : 1

Pin #	Pin Assignments
1	USB D-
2	USB ID
3	Digital Output 1 (Low side, 500 mA)
4	Digital Output 3 (Low side, 500 mA)
5	Frequency Input (Alternator and Mag)
6	Digital Input 1
7	Digital Input 3
8	A/D Input 2 (0-5v, 4-20 mA, Resistive)
9	A/D Input 4 (0-5v, 4-20 mA, Resistive)
10	Analog Output (0-5 V)
11	N/C
12	N/C
13	USB Shield
14	CAN -
15	Digital Output 2 (Low side, 500 mA)
16	Digital Output 4 (Low side, 500 mA)
17	Freq Input Return
18	Digital Input 2
19	A/D Input 1 (0-5v, 4-20 mA, Resistive)
20	A/D Input 3 (0-5v, 4-20 mA, Resistive)
21	A/D Gnd
22	Analog Output Gnd
23	N/C
24	USB D+
25	USB Vbus
26	CAN +
27	Ignition
28	Batt+
29	Batt-
30	Batt2+
31	N/C
32	N/C
33	N/C
34	RS485 -
35	RS485 +

## PIN SPECIFICATIONS FOR AMPSEAL STYLE CONNECTION

### Accessories

P/N 78-00-0824 – Wiring Harness, Loose leads, 24 inches

P/N 78-09-0077 – Programming Harness



## Configuration Information

Follow these steps to download a custom configuration to the PV485 display:

Step	Action
1	Ensure that PowerVision is open on your computer.
2	Connect the PV485 to the computer with the programming harness.  <b>NOTE:</b> If PowerVision does not detect the display, go to the Adapter Properties. Select IPV4 properties, then change the IP address to 192.168.0.1 and the Subnet mask to 255.255.255.0.
3	Create your custom configuration file within PowerVision.
4	Deploy the configuration file to the PV485.

Follow these steps to download a custom configuration using a USB drive:

Step	Action
1	Create your custom configuration file within PowerVision.
2	Save the file to a USB drive.
3	Connect the USB drive to the USB port on the connector provided with the programming kit.
4	Turn off the PV485, and turn it back on while holding down display key 5 (the button on the far right). Continue to hold the button a few more seconds, then release. This will put the display into the bootloader.
5	Use the corresponding keys to the up/down arrows to find the desired file. Use the corresponding right arrow key to select and continue. The right arrow turns green; press again to confirm.
6	When the installation is complete, a check mark is displayed in the middle of the screen. The PV485 will power cycle and boot to the new configuration.

# Specifications

## Technical

---

**Display:** Bonded 4.3" color transmissive TFT LCD

**Resolution:** WQVGA, 480 x 272 pixels, 16-bit color

**Aspect Ratio:** 16:9

**Orientation:** Landscape

**Backlighting:** LED, 900-1000 cd / m<sup>2</sup> (30,000 hr lifetime)

**Microprocessor:** Freescale iMX35 32bit, 532Mhz

**Operating System:** QNX Real-Time Operating System

**Flash Memory:** 256 MB (expandable to 8GB)

**RAM:** 128 Mbytes DDR2 SDRAM

**Operating Voltage:** 6-32 VDC, protected against reverse polarity and load-dump

**Power Consumption:** 10W max

**CAN:** (1) CAN 2.0B

**Serial:** (1) RS485 (Modbus Master/Slave)

**Protocols:** J1939; FreeForm Can support

**Connection:** (1) 35-pin AMP seal connector (AMP776231-4)

**Keyboard:** 5 tactile buttons

**USB:** (1) USB 2.0 host (full speed)

**Digital Inputs:** (3) digital inputs

**Digital Outputs:** (4) low side open-drain, capable of sinking 500 mA

**Analog Inputs:** (6) total, (4) software configurable (0-5V, 4-20mA, Resistive) + Battery Voltage + 2nd Battery Voltage

**Analog Outputs:** (1) 0-5V

**Frequency Inputs:** (1) Alternator and Magnetic Pickup

**Real-time Clock:** with battery backup

## Environmental

---

**Operating Temperature:** -40°C to +85°C

**Storage Temperature:** -40°C to +85°C

**Protection:** IP 67, front and back.

**Emissions/Immunity:** SAE J1113 or customer-specified; (CE) - EN61000-6-2, EN12895, ISO 13766

**Vibration:** Random vibration, 7.86 Grms (5-2000 Hz), 3 axis

**Shock:** ± 50G in 3 axis

## Mechanical

---

**Case Material:** Polycarbonate/ABS

# Mounting Templates

## Dash-Mount Template

**NOTE:** These templates are as close as possible to the actual size needed for unit placement. Always remember to measure twice to ensure correctness before cutting the dash material.

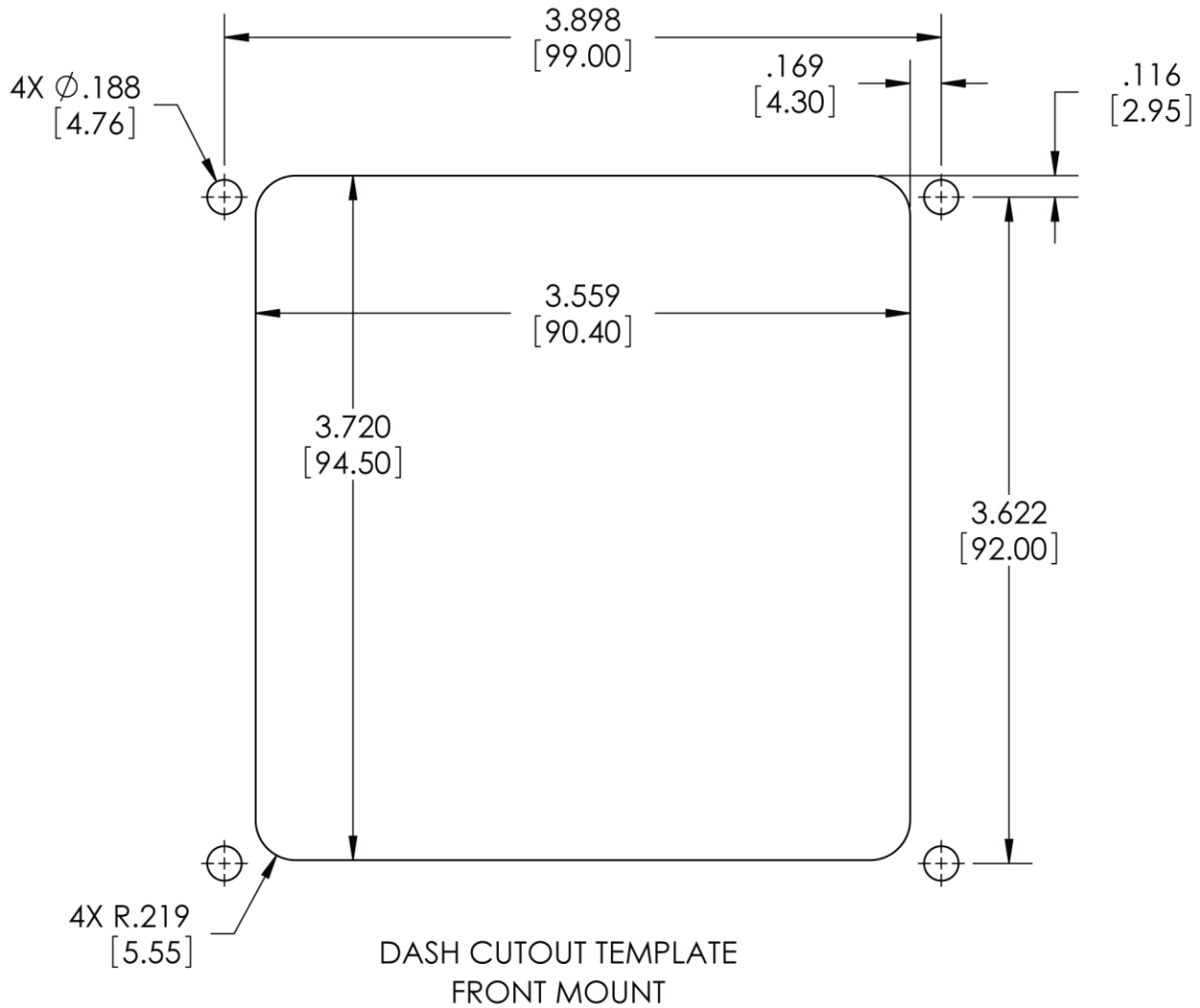



# Rear-Mount Bracket Template

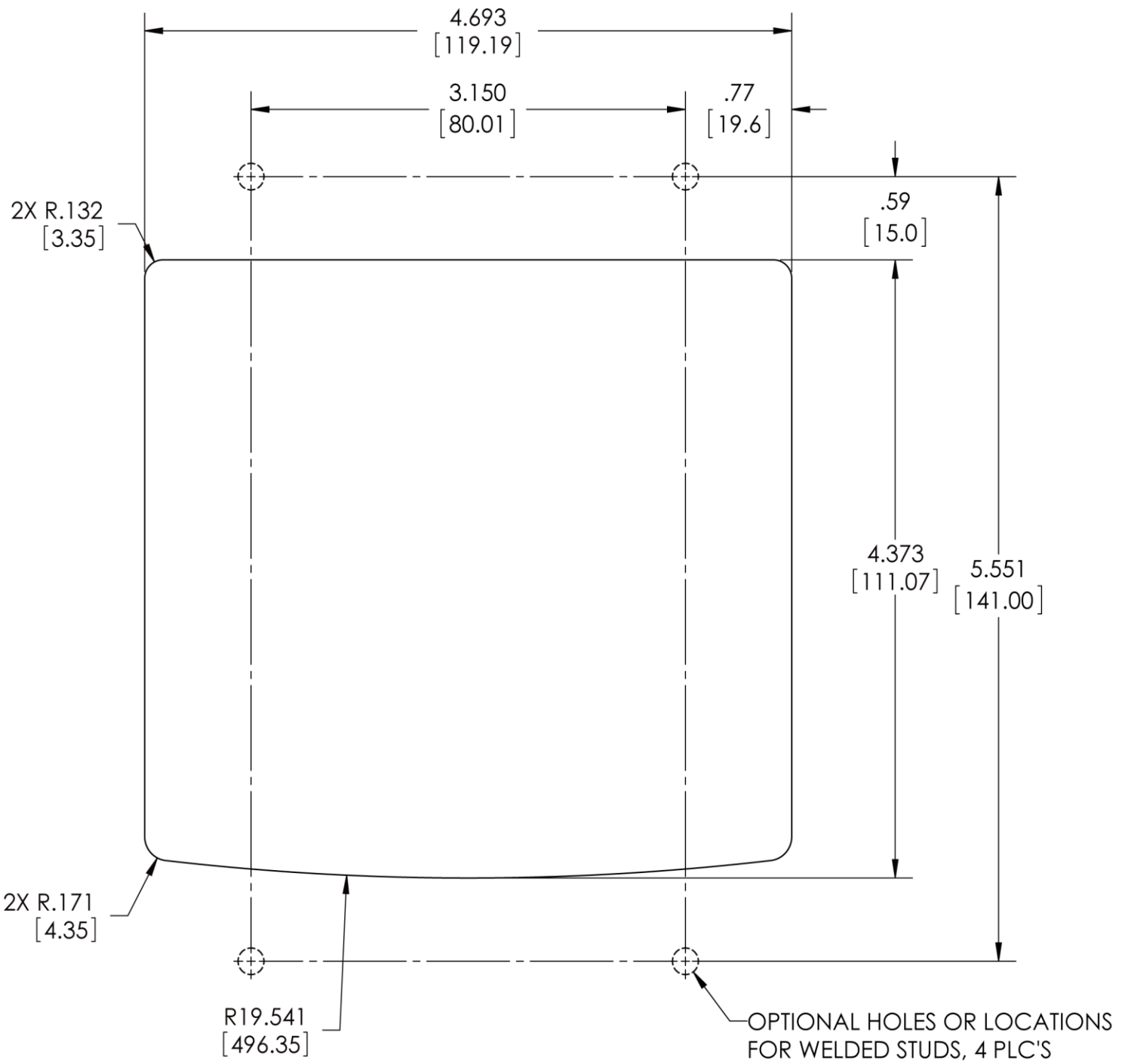

DASH CUTOUT TEMPLATE  
BACK MOUNT



# PV485 Connection with Power

## PV485 back view

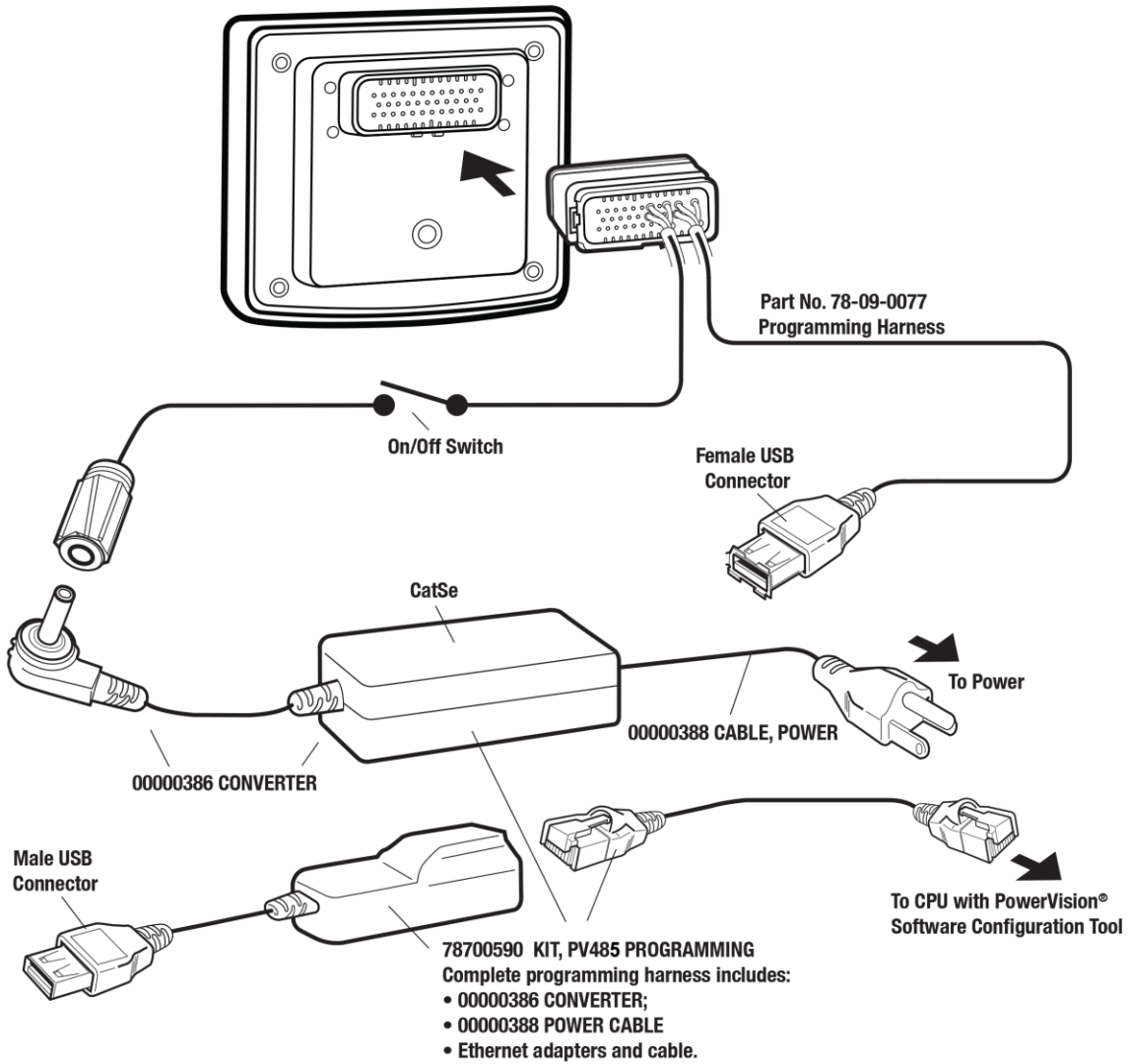

*In order to consistently bring you the highest quality, full-featured products, we reserve the right to change our specifications and designs at any time. MURPHY products and the Murphy logo are registered and/or common law trademarks of Enovation Controls, LLC. This document, including textual matter and illustrations, is copyright protected by Enovation Controls, LLC, with all rights reserved. (c) 2017 Enovation Controls, LLC. A copy of the warranty may be viewed or printed by going to [www.murphybyenovationcontrols.com/warranty](http://www.murphybyenovationcontrols.com/warranty)*

**ENOVATION CONTROLS CORPORATE HEADQUARTERS**  
5311 S 122ND EAST AVENUE  
TULSA, OK 74146

**ENOVATION CONTROLS LTD. – UNITED KINGDOM**  
CHURCH ROAD LAVERSTOCK  
SALISBURY SP1 1QZ UK

**MURPHY INTERNATIONAL TRADING – CHINA**  
SUITE 1704, ANTAI BUILDING, 107 ZUNYI RD  
SHANGHAI, 2000 S1 CHINA

**ENOVATION CONTROLS INDIA PVT. LTD.**  
301, 3RD FLOOR, KRSNA CHAMBERS,  
11 GALAXY GARDENS, NORTH MAIN ROAD,  
KOREGAON PARK, PUNE 411001,  
MAHARASHTRA, INDIA

**U.S. SALES & SUPPORT**

**MURPHY PRODUCTS**  
PHONE: 918 317 4100  
EMAIL: [SALES@ENOVATIONCONTROLS.COM](mailto:SALES@ENOVATIONCONTROLS.COM)  
[WWW.ENOVATIONCONTROLS.COM](http://WWW.ENOVATIONCONTROLS.COM)

**MURPHY INDUSTRIAL PANEL DIVISION**  
PHONE: 918 317 4100  
EMAIL: [IPDSALES@ENOVATIONCONTROLS.COM](mailto:IPDSALES@ENOVATIONCONTROLS.COM)

**INTERNATIONAL SALES & SUPPORT**

**EUROPE, MIDDLE EAST, AFRICA**  
PHONE: +44 1722 410055  
EMAIL: [SALES@ENOVATIONCONTROLS.EU](mailto:SALES@ENOVATIONCONTROLS.EU)

**CHINA**  
PHONE: +86 21 6237 5885  
EMAIL: [APSALES@ENOVATIONCONTROLS.COM](mailto:APSALES@ENOVATIONCONTROLS.COM)

**LATIN AMERICA & CARIBBEAN**  
PHONE: +1 918 317 2500  
EMAIL: [LASALES@ENOVATIONCONTROLS.COM](mailto:LASALES@ENOVATIONCONTROLS.COM)

**INDIA**  
PHONE: +91 91581 37633  
EMAIL: [INDIASALES@ENOVATIONCONTROLS.COM](mailto:INDIASALES@ENOVATIONCONTROLS.COM)



FM 28221 (Tulsa, OK - USA)  
FM 29422 (UK)